



AGD Equipment Limited

SALES • RENTAL • SERVICE • PARTS

MINI CRANES

CRAWLER CRANES

TELESCOPIC CRANES

**PILING RIGS
AND EQUIPMENT**

01789 292227

info@agd-equipment.co.uk

AGD Equipment Limited
Avonbrook House
198 Masons Road
Stratford-upon-Avon
Warwickshire
CV37 9LQ
United Kingdom



**MÜLLER MS-48 HFV
Vibratory Hammer
with MS-A 690
Power Pack**

www.agd-equipment.co.uk

MÜLLER MS-48 HFV Vibratory Hammer

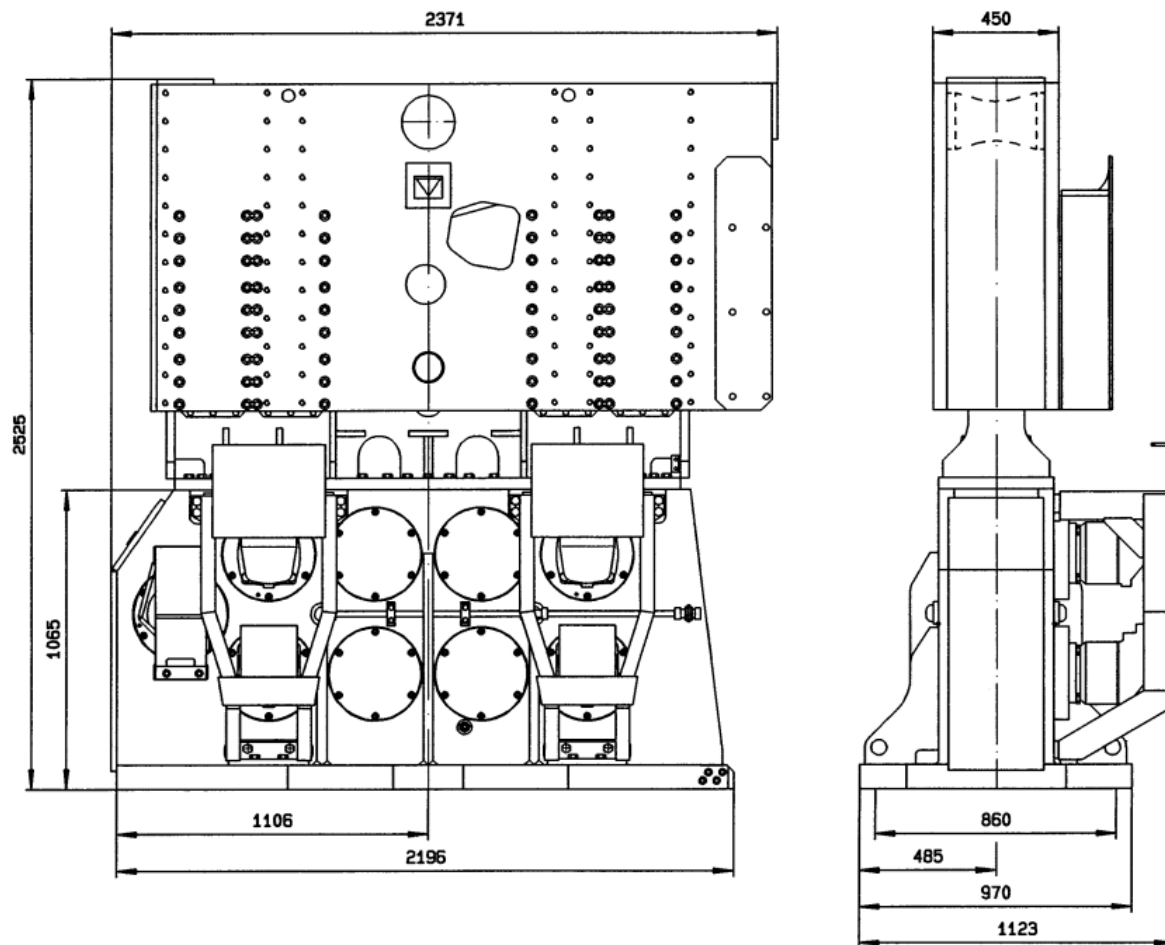

Technical Data

Centrifugal Force Max.	kN	2960
Eccentric Moment	Kgm	0-48
Oscillation Frequency Max.	Hz	39
Speed Max.	1/min	2350
Pulling Force Max.	kN	600
Weight*	kg	9700
Weight (dynamic)*	kg	6520
Amplitude Max.	mm	14.7
Power Max. (Standard)	kW	823
Power Max. (Option)	kW	682
Volume Input Max. (Standard)	l/min	1410
Volume Input Max. (Option)	l/min	1170
Working Pressure Max. (Standard)	bar	350
Working Pressure Max. (Option)	bar	350

* without clamping device

Recommended power pack: Type MS-A 420

Recommended clamping device: Type MS-U 360

MÜLLER MS-A 690W Power Pack

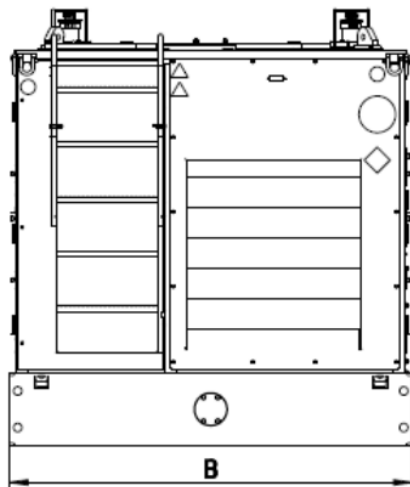
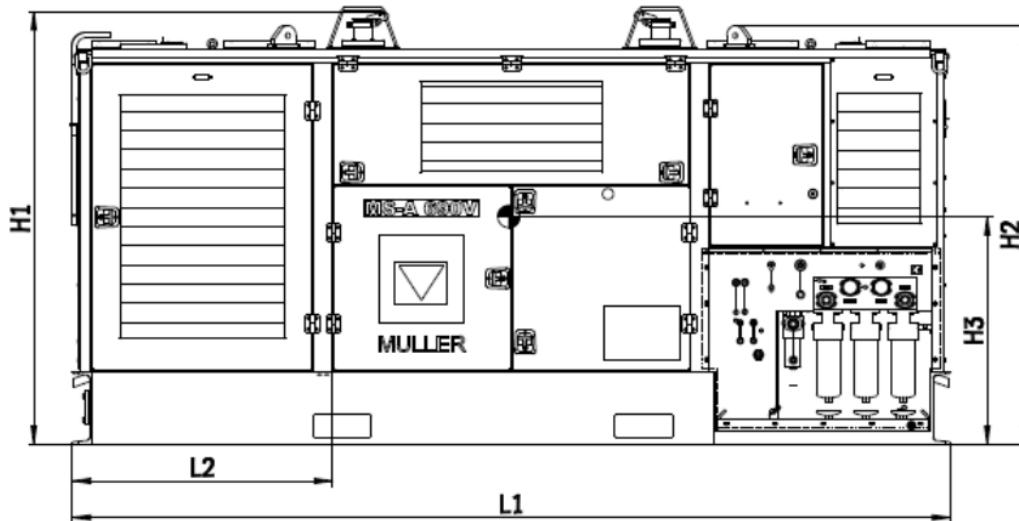

Lashing capacity 4t
Lashing ring use only for lashing,
not for lifting.

L1	L2	B	H1	H2**	H3	H4
4800mm	2400mm	2200mm	2365mm	2290mm	1245mm	1900mm

** Shipping height (exhaust pipes and rain cover disassembled)

Lifting Instruction

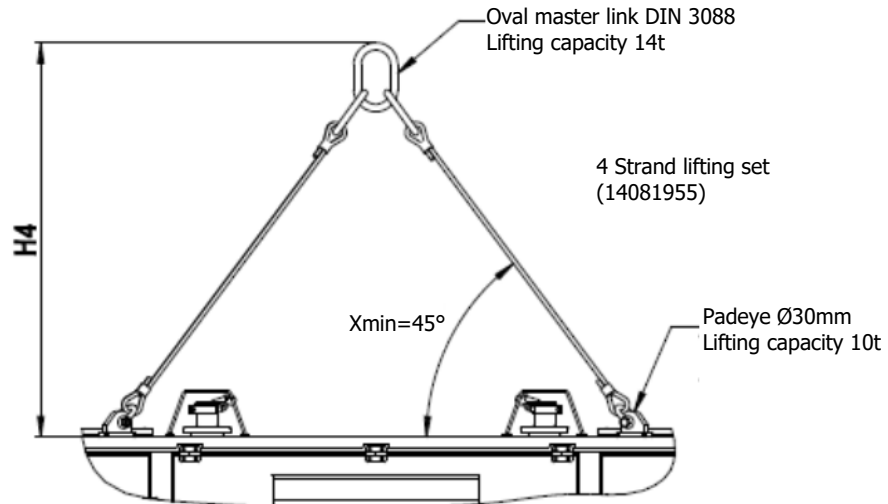

Technical Data

Diesel Engine	CAT C 9.3B
Exhaust Certification EU/EPA	Stage 5
Performance	2 x 340 = 680kW
Speed	2000 min ⁻¹
Fuel Tank Volume Max.	1400 litres
Hydraulic Tank Volume Max.	500 litres
Weight without Fuel	10600 kg

Pump Equipment

Vibrator Drive Pumps	2 x 280 cm ³ /U
Delivery Max.	2 x 540 = 1080 l/min
Working Pressure Max.	380 bar

Clamp Hydraulic Pump	10 cm ³ /U
Delivery	20 l/min
Working Pressure Max.	350 bar

Pump for Amplitude	8 cm ³ /U
Delivery	20 l/min
Working Pressure Max.	250 bar

Cooler Equipment

Hydraulic Oil Cooler	
Oil-Air-Radiator	
Cooling Capacity	120 kW

Vibrator Gear Oil Cooler	
Oil-Air-Radiator	
Cooling Capacity	* kW

* Optional – dependent on vibrator